

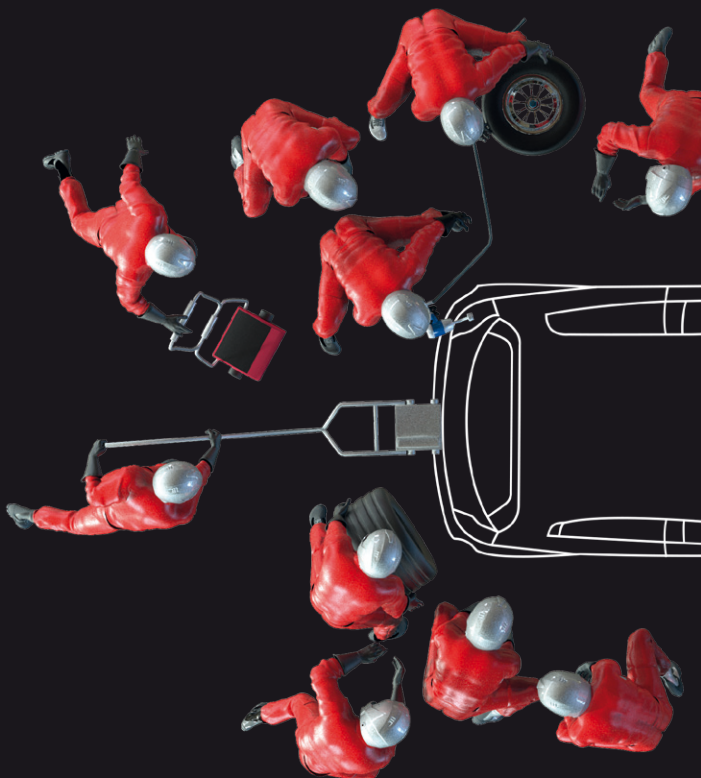

## MOBILE

professional



- Furgone di dimensioni compatte, con altezza inferiore ai 2 metri, ideale per muoversi sia in spazi aperti che chiusi
- *A compact van, less than 2 metres high, ideal for moving in both open as well as closed spaces.*



- Completamente autonomo, è in grado di lavorare anche solo grazie alle batterie in dotazione. Dove possibile può funzionare sfruttando la rete elettrica o l'alternatore del veicolo.
- *Completely autonomous, able to work even only with the batteries supplied. Where possible it can operate using the mains or the vehicle alternator.*



- Niente bombole o generatori, può operare anche in parcheggi interrati o sotterranei.
- *No cylinders or generators, it can also operate in underground car parks.*



- Massima ergonomia ed efficienza: si lavora all'esterno del furgone, con lo smontagomme stabilmente appoggiato al terreno e l'equilibratrice traslata all'esterno. Esattamente come essere nella propria officina.
- *Maximum ergonomics and efficiency: you work outside the van, with the tyre changer firmly resting on the ground and the wheel balancer moved outside. Exactly like being in your own workshop.*



- Possibilità di collegare e utilizzare dispositivi esterni come ad esempio elettrotensili, crick o avvitatori per le varie operazioni di lavoro mediante le prese elettriche a 220 Volt e la linea pneumatica a 10 Bar disponibile.
- *Possibility to connect and use external devices such as power tools, jacks or power screwdrivers for the various operations using the 220 Volt power sockets and the 10 Bar compressed air line provided.*

# MOBILE SERVICE

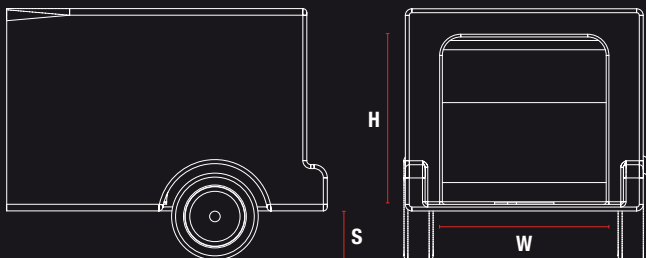

### Caratteristiche minime furgone:

- Altezza da terra piano di carico (S): min. 540 mm – max. 600 mm a vuoto.  
Min. 450 mm a pieno carico
- Distanza max. tra fine paraurti e chiusura porta posteriore (K): 200 mm
- Portata a pieno carico: 1000 kg

### Minimum van features:

- Loading bed height above ground (S): min. 540 mm – max. 600 mm without load.  
Min. 450 mm with full load
- Max. distance between bumper end and rear door closure (K): 200 mm
- Capacity with full load: 1000 kg

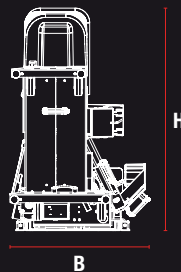
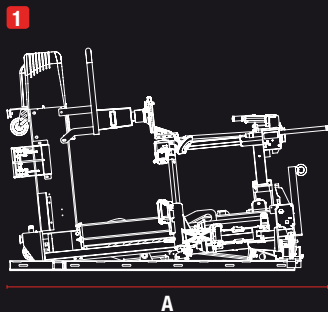

### Dimensioni minime porta posteriore furgone:

- Altezza porta (H): 1280 mm
- Larghezza porta (W): 1250 mm
- Lunghezza piano di carico (L): 2300 mm

### Minimum dimensions of rear van door:

- Door height (H): 1280 mm
- Door width (W): 1250 mm
- Loading bed length (L): 2300 mm

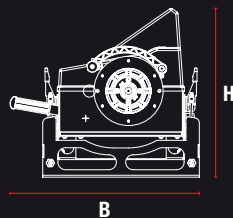
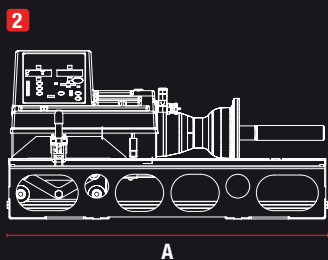

### Dimensioni minime porta laterale furgone:

- Altezza porta: non vincolante
- Larghezza porta (P): 1000 mm
- Altezza da terra piano di carico: Min. 450 mm a pieno carico
- Distanza max. tra portiera e slitta (B): 130 mm

### Minimum dimensions of side van door:

- Door height: not binding
- Door width (P): 1000 mm
- Loading bed height above ground: Min. 450 mm with full load
- Max. distance between door and slide (B): 130 mm

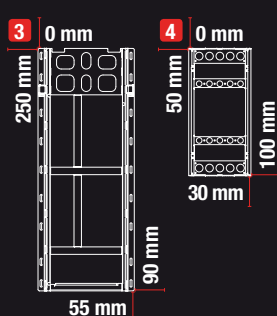
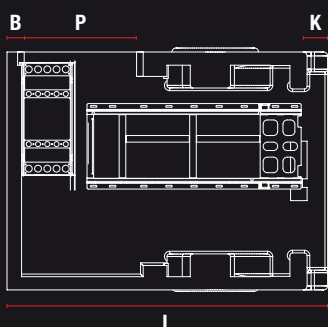

### 1 Ingombri ARTIGLIO 55:

- Lunghezza massima (A): 1807 mm
- Larghezza massima (B): 821 mm
- Altezza massima (H): 1249 mm

### Overall dimensions of ARTIGLIO 55:

- Maximum length (A): 1807 mm
- Maximum width (B): 821 mm
- Maximum height (H): 1249 mm

### 2 Ingombri EM43 SLIDE:

- Lunghezza massima (A): 863 mm
- Larghezza massima (B): 510 mm
- Altezza massima (H): 455 mm

### Overall dimensions of EM43 SLIDE:

- Maximum length (A): 863 mm
- Maximum width (B): 510 mm
- Maximum height (H): 455 mm

### 3 Ingombri minimi per posizionamento slitta fissa ARTIGLIO 55

Minimum overall dimensions for positioning the fixed slide of ARTIGLIO 55

### 4 Ingombri minimi per posizionamento slitta fissa EM43 SLIDE

Minimum overall dimensions for positioning the fixed slide of EM43 SLIDE



**SMONTAGOMME ARTIGLIO 55 *Leva la Leva***  
**ARTIGLIO 55 *Leva la Leva* Tyre Changer**

Ideale per ruote vetture, SUV e veicoli commerciali fino a 30". Smontagomme che utilizza la tecnologia "**Leva la Leva**" eliminando quindi completamente la fatica fisica e il rischio legato al danneggiamento di cerchi e pneumatici particolarmente delicati o difficili, e abbattendo contemporaneamente i tempi di lavoro su tutti i tipi di ruote di recente progettazione (dai low profile a tutti i run flat).

*Ideal for car, SUV and commercial vehicle wheels up to 30". Tyre changer that uses the "**Leva la Leva**" technology, completely eliminating, therefore, the physical effort and risk associated with damage to particularly delicate or difficult wheel rims and tyres, and simultaneously reducing working time on all types of recent design wheels (from low profile to all run-flat).*



**Movimento dello smontagomme assistito pneumaticamente.** Nessuna fatica e tempi rapidissimi per far uscire e rientrare lo smontagomme dal furgone.

***Pneumatically assisted tyre changer movement.*** *No effort and very quick to get the tyre changer in and out of the van.*

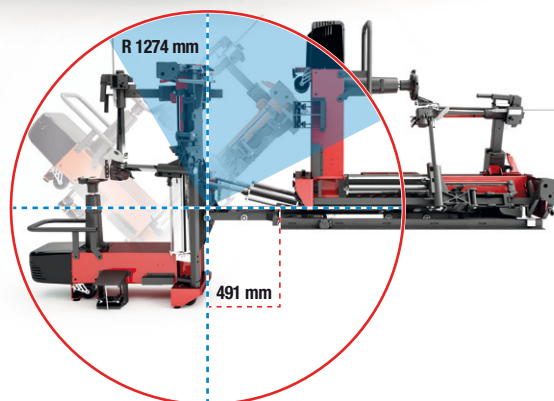



**RICCA POSSIBILITÀ DI DOTAZIONE  
E PERSONALIZZAZIONE  
DELL'ALLESTIMENTO DEL FURGONE,  
PER RISPONDERE AD OGNI ESIGENZA.**  
*MANY STANDARD AND CUSTOMISED VAN  
CONFIGURATIONS TO MEET EVERY NEED.*



#### **Equilibratrice - Wheel balancer**

**Equilibratrice elettronica a microprocessore per ruote fino a 65kg, con pannello comandi a doppio display progettato per un uso intuitivo di tutte le funzioni disponibili. La bassa velocità di equilibratura riduce i tempi di lancio e limita i rischi dovuti ad organi in rotazione. La traslazione all'esterno del furgone è manuale.**

***Electronic microprocessor wheel balancer for wheels up to 65 kg, with double display control panel designed for intuitive use of all available functions. The low balancing speed reduces spin time and risks due to rotating bodies. Movement outside the van is manual.***



**COS'È?** Mobile Service è un furgone attrezzato con uno smontagomme **Leva la Leva**, una equilibratrice e un compressore azionati da batterie, per portare il tuo servizio alla ruota direttamente dal cliente.

**WHAT IS IT?** *Mobile Service is a van equipped with a **Leva la Leva** tyre changer, a wheel balancer and a compressor, all battery powered, to bring your wheel service directly to the customer.*

## INNOVATIVE SERVICE

solution in motion



**A CHI È RIVOLTO?** Ai gommisti, alle officine, alle stazioni di servizio, e in generale a chiunque opera nel servizio alla ruota e necessità di un mezzo ideale per il pronto intervento, la gestione di flotte, eventi automobilistici e qualunque altra attività a domicilio. Efficienza, redditività e soddisfazione del cliente finale.

**WHO IS IT ADDRESSED TO?** *To tyre centres, workshops, service stations and generally anyone working in wheel service who needs a vehicle ideal for breakdown service, fleet management, automotive events and any other on-site activities. Efficiency, profitability and customer satisfaction.*

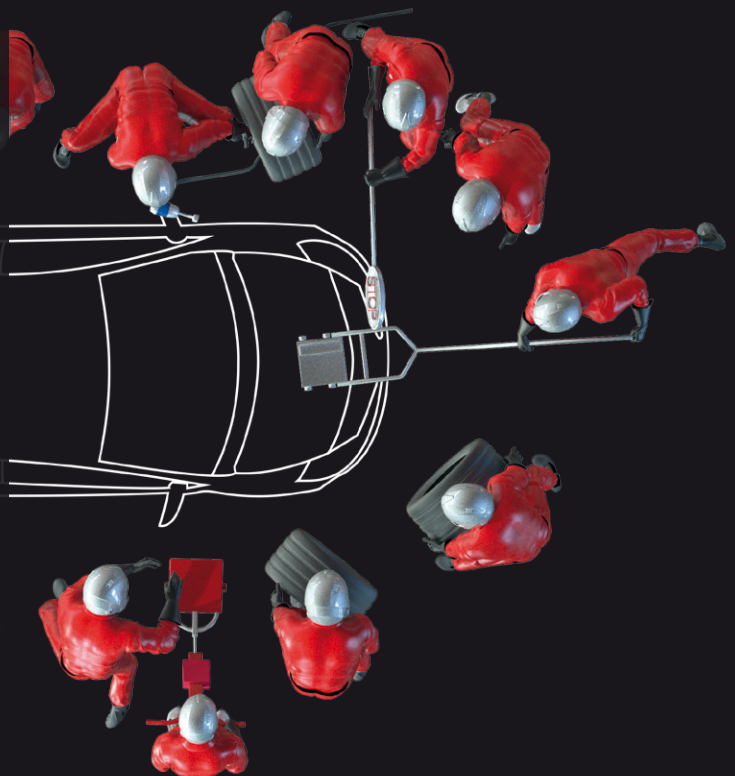

[www.corghimobileservice.com](http://www.corghimobileservice.com)



*Passion To Innovate*

NEXION SPA - ITALY

Società unipersonale soggetta a direzione e coordinamento di Minio srl - A sole shareholder Minio company

[www.corgchi.com](http://www.corgchi.com) - [info@corgchi.com](mailto:info@corgchi.com)

